

## Product details



SOLLER

### **XI washbasin mixer**

Ref: 85311125N EAN: 8413509261803

Acabado: Matte black

- Precise and smooth ceramic cartridge.
- Durable paint finish.
- Water flow limiter 5 L/min.
- Save up to 60% compared to a standard tap.
- Ideal for BREEAM and LEED projects.
- Easy Fix fast installation system.
- 3/8"-1/2" flexible inlet pipes included.
- Anti-limescale aerator.
- Without drain stopper.

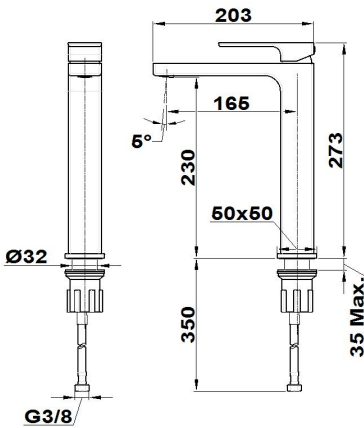

## Iconos



## Downloads

User guide

### Legal disclaimer:

\*Certain technical factors and features of our finishes may be altered due to possible variations in the configuration of your computer and/or printer; these data are therefore only approximate and not definitive. We regularly review our product specifications to improve their characteristics and warranties. Please request detailed information from our sales department for any building or refitting projects.